

MINIMUM OFFICE SIZE GUIDELINES

Revised July 1, 2016

Principles for Office Planning & Design in New Construction & Alterations

The University of Chicago seeks to provide an environment conducive to learning, teaching, working, and conducting research that values the diversity of its community. As such, the fundamental principles for office renovation and construction are guided by Universal Design, which supports the creation of spaces that are inherently accessible to people both with and without disabilities. For additional resources for Accessibility Plus please review references in Volume III D. Accessibility. Accessibility Plus typically for multiple and open office spaces.

- 1. Each enclosed office space shall be designed to accommodate an occupant and one guest who use standard wheelchairs.*
- 2. Required maneuvering clearances shall be provided at all room entrances and exits and within workstations.*
- 3. Minimum unobstructed 60" diameter turning circle or 60" x 60" t-turn space is required. The turning space may extend under furniture if required knee clearances are provided or if the furniture is movable.*
- 4. Minimum 36" wide unobstructed accessible paths shall be provided within the space for occupants and visitors.*
- 5. Minimum 80" ceiling height and headroom clearance shall be provided.*
- 6. Fixed furniture and equipment shall be provided in compliance with reach ranges and knee clearances.*
- 7. Minimum clearances shall be provided for an arrangement of furniture appropriate to the assigned space use.*
- 8. All minimum clearances and dimensions shall be clear and unobstructed, and shall allow for conventional tolerances and variances in construction and manufacturing.*
- 9. Examples of layouts for single occupant offices, double occupant offices, and open offices that conform to these principles are provided. Examples assume a standard work surface depth of 17"-25".*

*For single and smaller offices refer to Project Design Program or Owners Project Requirements for guidance for Accessibility Plus. Typically Accessibility Plus is not required for most small offices.

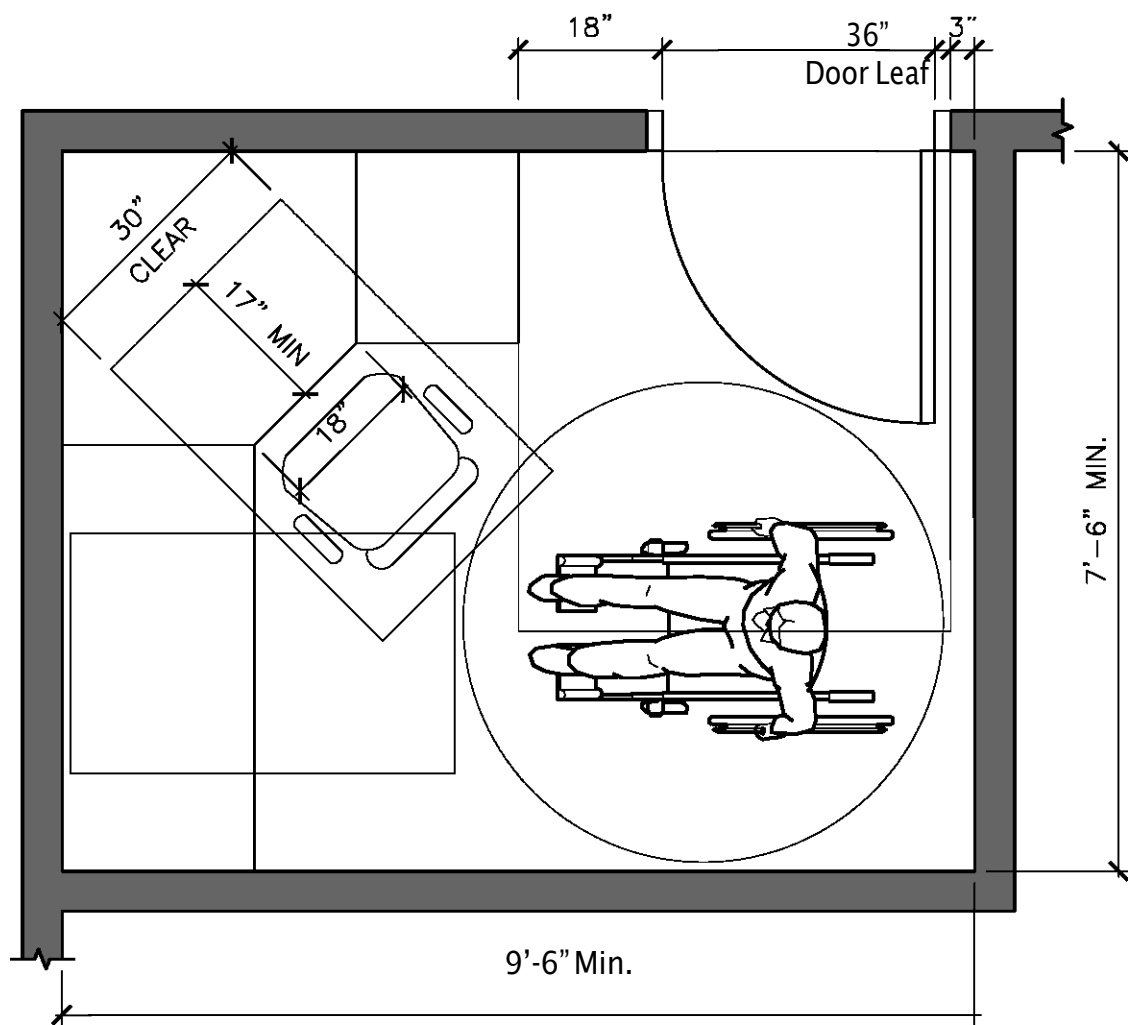

Option 1
Minimum Office Size Guidelines

Reference Vol. IV BLANK for Accessibility Plus Standards

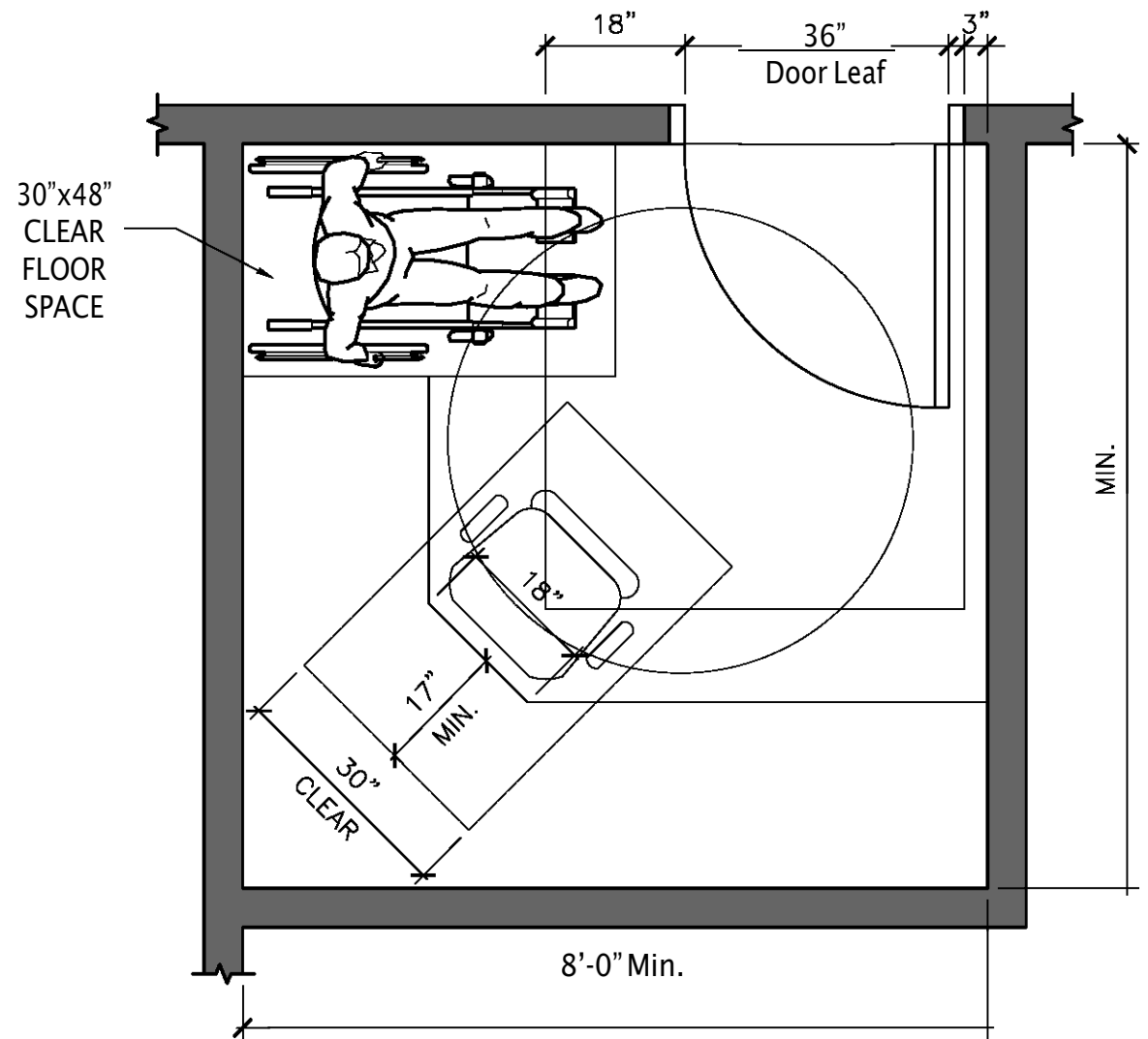

Option 2
Minimum Office Size Guidelines

Reference Vol. IV BLANK for Accessibility Plus Standards

Minimum Office Guideline for Accessible Open-Office Layouts

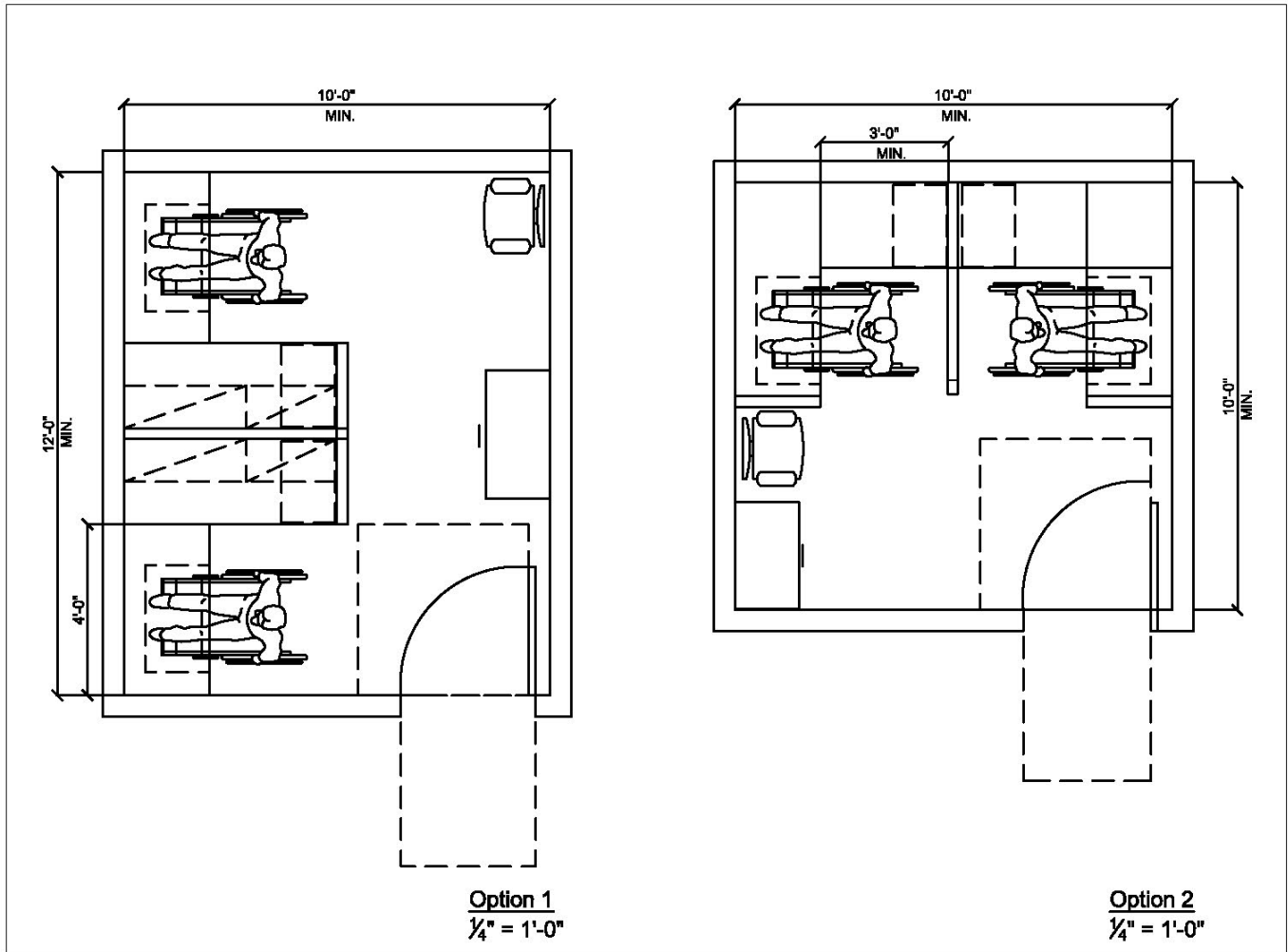

- Examples of conforming two-person office layouts are shown.

Minimum Office Guideline for Accessible Open-Office Layouts

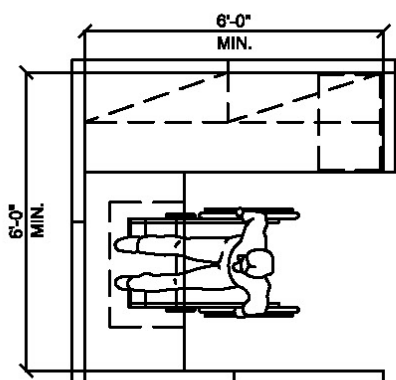

Option 1
 $\frac{1}{4}'' = 1'-0''$

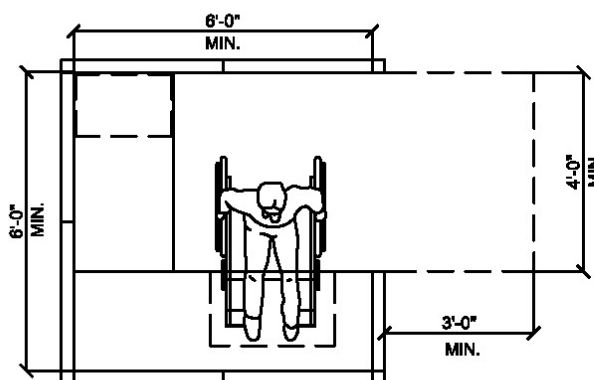

Option 2
 $\frac{1}{4}'' = 1'-0''$

- Examples of conforming two-person office layouts are shown.